

INSTALLATION INSTRUCTIONS

FOR

INSULATED RAIL JOINTS TENCONI

73C1 - 4 hole

CAUTION !

This leaflet contains important instructions to be strictly complied with for the installation and maintenance of the Tenconi Insulated Joints.

- **Do not install the Tenconi Insulated Joints if some of its components are damaged, lost or missing. Be sure to entrust the installation only to skilled personnel using the right equipment.**
- **Be careful when handling the Tenconi Insulated Joints: they are heavy and can slip if placed on smooth, unsteady or inclined surfaces!**
- **If a leak or failure is detected, the Tenconi Insulated Joints have to be replaced immediately!**



Mechanical Workshop CH-6780 AIROLO
Tel. +41 91 873 30 00
Fax. +41 91 873 30 01

SWITZERLAND

Installation and handling Instructions

It can be installed on site – or in workshop – using basic permanent way tools and skills. To avoid handling injuries or incorrect installation, only skilled and duly trained personnel has to be entrusted with the installation of the Tenconi insulated Joints.

If still in good conditions, properly maintained and cleaned, the Tenconi Insulated Joints can be disassembled and re-used. The TENCONI Joint is a precision system with bolts having a tight clearance in the rail web holes. These must be jig-drilled either in factory or on site.

On site power rail drills with appropriate templates suitable for drilling to the tolerances given in these instructions are available on the market.

1 COMPLETE SET

POS.	DESCRIPTION	N° OF PIECES
1	BIG INSULATED FISHPLATE	1
2	SMALL INSULATED FISHPLATE	1
3	END POST	1
4	WASHERPLATE	4
5	STUD	4
6	NUT	8

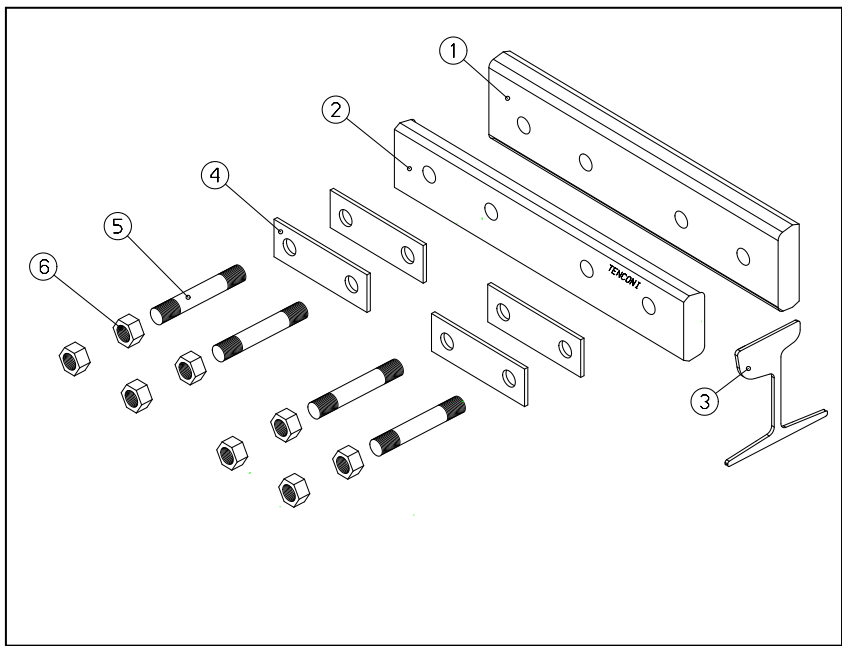

2 PREPARATION OF THE RAIL ENDS

- Check that the rail ends are aligned.
- Check that the hole spacing and hole diameter are correct :
 $A = 185 \pm 0,2 \text{ mm}$ $B = 120 \pm 0,2 \text{ mm}$
 $C = 73 \pm 0,2 \text{ mm}$ $\varnothing = 25 \pm 0,2 \text{ mm}$
- Check that the gap between rail ends is correct (**4mm**) and the faces are parallel.
- Wire brush the fishing chambers on approximately 600 mm on both rail ends.

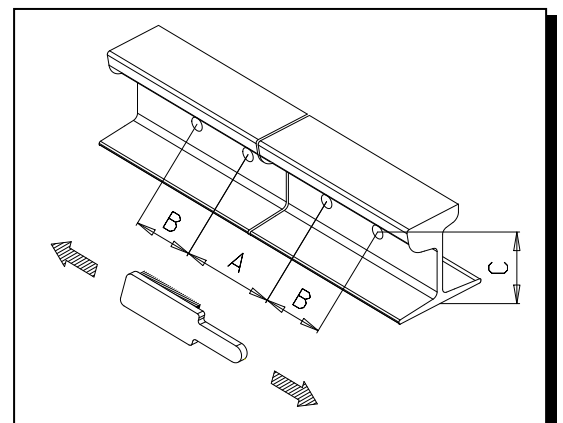

3

JOINT ASSEMBLY

- a) Install the End Post (**pos 3**).
- b) Install one nut (**pos 6**) on each stud (**pos 5**).
- c) Install one insulated fishplate (**pos 1** or **pos 2**) taking care that the ribs are toward the rail web and that the writing TENCONI are positioned on the top side.
- d) Install two washerplates (**pos 4**) on that fishplate and insert the studs with the nuts using a light hammer.
- e) Install the second insulated fishplate (**pos 2** or **pos 1**) as in c).
- f) Install the two washerplates (**pos 4**) and the nuts (**pos 6**).

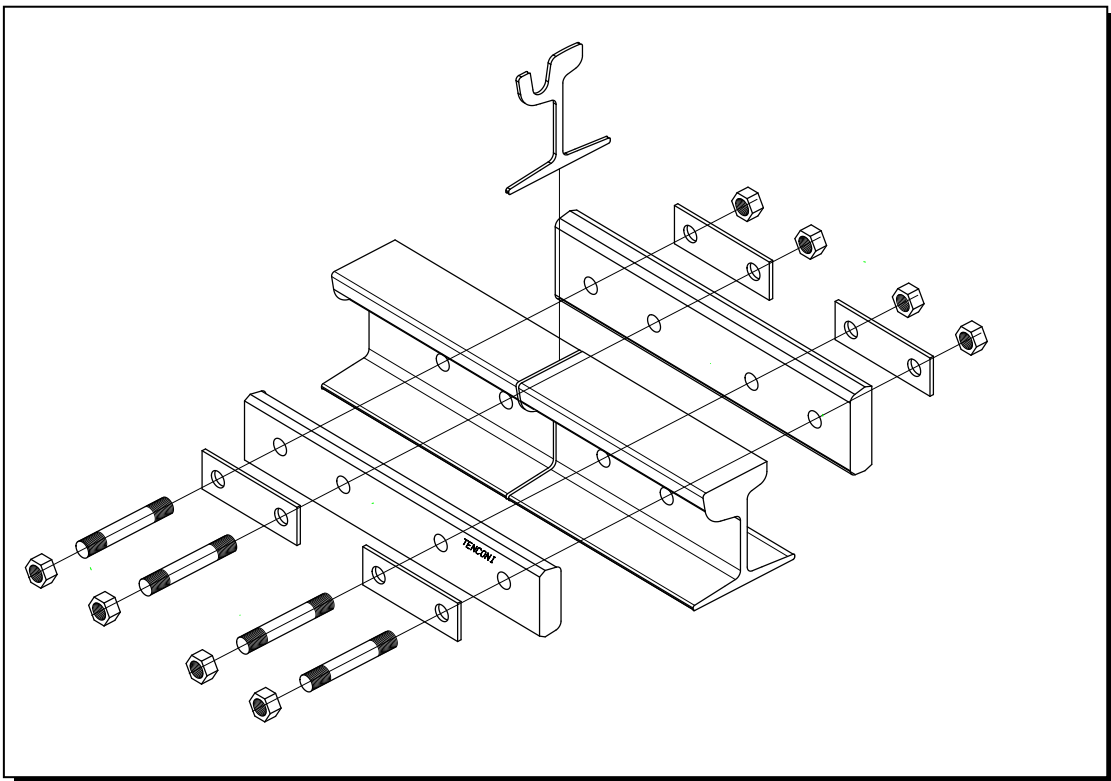

4

JOINT LOCKING

- a) Tighten all the nuts slightly.
- b) Tighten the nuts completely with a torque spanner in the sequence **2, 3, 1** and **4**.
- c) The torque of **760Nm** shall be applied.
- d) Remove the excess plastic of the End Post from the running surface using a chisel or file.

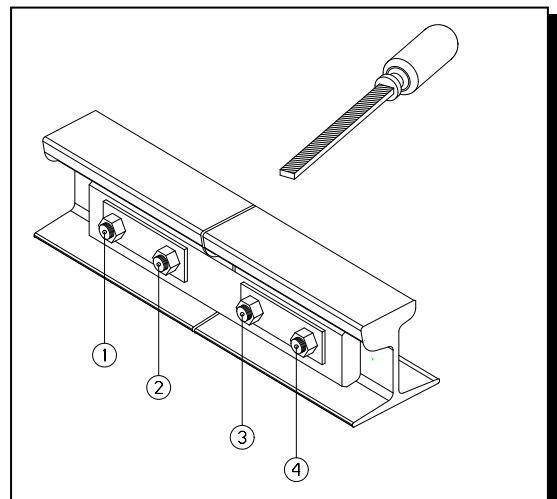

5 RETIGHTENING OF THE NUTS

- a) One month after installation the nuts must be retightened using the above indicated torque value.

Maintenance Instructions

The Tenconi Insulated Joints need to be regularly maintained and cleaned. In particular iron dust traces and other scraps left by trains on the rails can create conductivity between two rail ends, what would disable the operation of the insulated joints.

6 MAINTENANCE

- a) Maintenance is limited to periodical cleaning of the fishplate, particularly around the End Post area in order to avoid electric contacts between the two rails.
b) Maintenance frequency depends on traffic and local environmental conditions.

7 SPECIAL INSTRUCTION

- a) During periods of cold weather the opening of the gap at the End Post may be observed. This event does not represent a failure of the joint, whose integrity and functionality are still guaranteed.

LOCAL REPRESENTATIVE

MANUFACTURER



AWI MASKIN AB
Hammarvägen 19
SE-23237 Arlöv

www.awi.se

Jan Nilsson
Managing Director

Tel: +46 150-727 17

Fax: +46 150-727 49

Mobil: +46 70-545 25 82

E-mail: jan.nilsson@awim.se

Oscar Månsson
Orders

Tel: +46 40 43 99 54

Fax: +46 40 41 65 75

Mob: +46 707 20 17 31

E-mail: oscar.mansson@awim.se



Tenconi SA
Via della stazione 50
6780 Airolo
Switzerland

Tel: +41 91 873 30 00

Fax: +41 91 873 30 01

E-Mail: tenconi@tenconi.ch

Web: www.tenconi.ch