

INSTALLATION INSTRUCTIONS

FOR

INSULATED RAIL JOINTS TENCONI

50 E3 (BV 50) SE - 6 hole HT with ferrules

Please read the installation instructions and make sure that you understand them fully.

CAUTION !

This leaflet contains important instructions to be strictly complied with for the installation and maintenance of the Tenconi Insulated Joints.

- **Do not install the Tenconi Insulated Joints if any of their components are damaged, lost or missing. Be sure to entrust the installation to skilled personnel only, using the right equipment.**
- **Be careful when handling the Tenconi Insulated Joints: they are heavy and can slip if placed on smooth, unsteady or inclined surfaces!**
- **If failure, damaged or missing components are detected, the Tenconi insulated rail joint must be replaced immediately.**



Mechanical Workshop
Tel. +41 91 873 30 00
Fax. +41 91 873 30 01

CH-6780 AIROLO

SWITZERLAND

CONTENTS:

• Chapter 1	General description
• Chapter 2	Complete set
• Chapter 3	Preparation of the rail ends
• Chapter 4	Joint assembly
• Chapter 5	Joint locking
• Chapter 6	Maintenance
• Chapter 7	Notes

1 GENERAL DESCRIPTION

The **Tenconi** Insulated Joint, made in Switzerland by **Tenconi SA**, is a **dry mechanical joint**. It can be easily installed on site - or in the work shop - using basic Permanent Way tools.

The Tenconi Joint is a precision item therefore the drilling of the rail web must be performed according installation or specific indication given by the entrusted Railway Authority.

2 COMPLETE SET

POS.	DESCRIPTION	N° OF PIECES
1	INSULATED FISHPLATE	2
2	END POST	1
3	LOCK WASHERPLATE	2
4	WASHERPLATE	2
5	BOLT	6
6	NUT	6
7	FERRULE	6

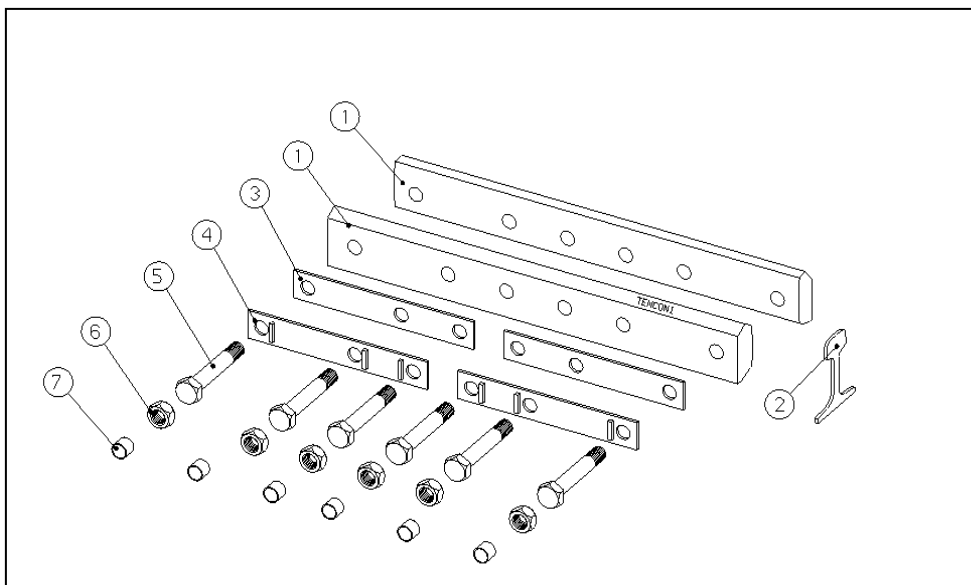

3 PREPARATION OF THE RAIL ENDS

a) Verify alignment of both rails.

b) Hole spacing:

$$\begin{aligned} \mathbf{A} &= 52.5^{+0.0}_{-0.3} \text{ mm} & \mathbf{B} &= 252.5 \pm 0.3 \text{ mm} & \mathbf{C} &= 402.5 \pm 0.3 \text{ mm} \\ \mathbf{D} &= 67 \pm 0.2 \text{ mm} & \mathbf{E} &= 4 \text{ mm} \end{aligned}$$

c) Hole diameter:

$$\varnothing = 33 \pm 0.2 \text{ mm}$$

Rail web holes chamfering and cold expansion may be performed **if requested** using appropriate tools.

d) Grind flush the rail fish chambers on both sides and remove any marking with appropriate tools.

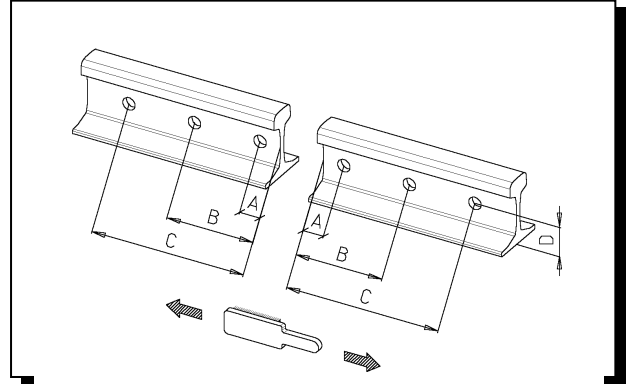

4 JOINT ASSEMBLY

Note: Ferrules have to be used only if the rail web hole is $\varnothing 33$ mm.

a) Insert the End Post (**pos 2**).

b) Install one insulated fishplate (**Pos. 1**). The factory marking on the insulated fishplate must be **always** on the top and must be visible.

c) Install the two lock washer plates (**pos 4**) on that fishplate and insert the bolts.

d) Install the second insulated fishplate (**pos 1**) as in b).

e) Install the two plain washer plates (**pos 3**) and turn the nuts (**pos 6**).

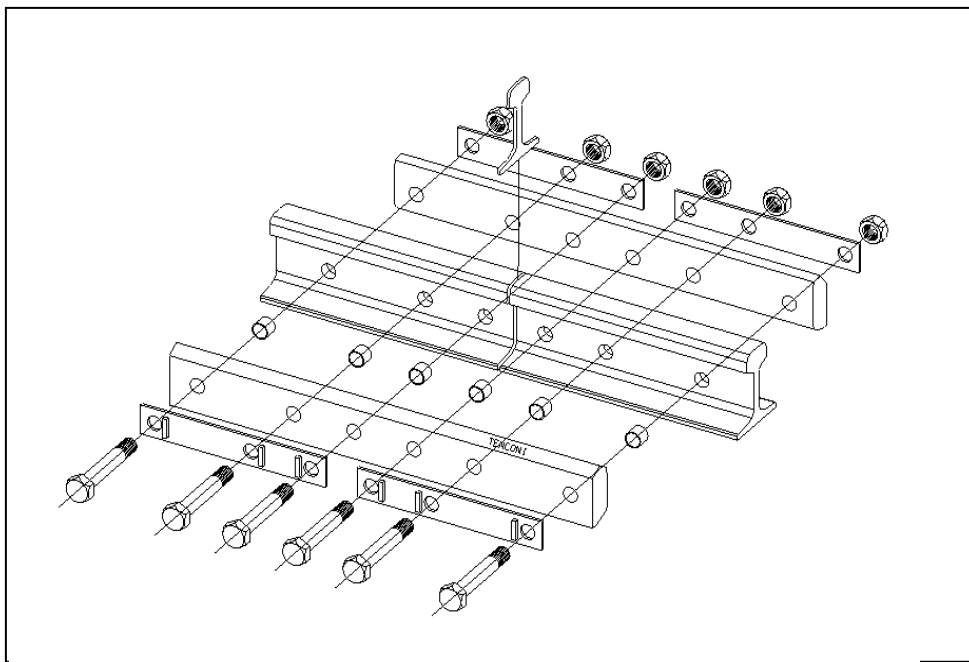

5 JOINT LOCKING

- a) Tighten all the nuts slightly.
- b) Tighten the nuts completely with a torque spanner in the sequence **3,4,2,5,1** and **6**.
- c) The torque for this item must be **950Nm**.
- d) Grind flush the End Post using appropriate tools.

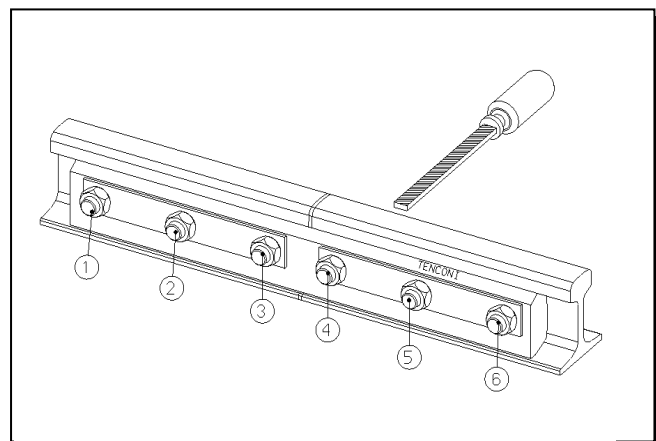

6 MAINTENANCE

- a) Approximately 1 month after the installation we suggest retightening the bolts according "Installation instruction, page 4, chapter 5".
- b) Rail head bridging and iron dust mixed with grease and dirt may cause undesired electrical contact between the two rails therefore the Tenconi insulated joints need to be maintained and cleaned regularly to prevent mechanical and electrical signalling failure.
- c) **In case of loose bolts/nuts or missing/damaged components immediate action must be taken.**

7 NOTES

- a) During periods of cold weather the opening of the gap at the End Post may be observed. This event does not represent a failure of the joint, whose integrity and functionality are still guaranteed.

LOCAL REPRESENTATIVE

MANUFACTURER

AWI Maskin AB

AWI MASKIN AB
Hammarvägen 19
SE-23237 Arlöv

www.awi.se

Jan Nilsson

Managing Director

Tel: +46 150-727 17

Fax: +46 150-727 49

Mobil: +46 70-545 25 82

E-mail: jan.nilsson@awim.se

Oscar Månsson

Orders

Tel: +46 40 43 99 54

Fax: +46 40 41 65 75

Mob: +46 707 20 17 31

E-mail: oscar.mansson@awim.se

TENCONI SA

Tenconi SA
Via della stazione 50
6780 Airolo
Switzerland

Tel: +41 91 873 30 00

Fax: +41 91 873 30 01

E-Mail: tenconi@tenconi.ch

Web: www.tenconi.ch