

3 JOINT ASSEMBLY

- a) Install the End Post (**pos 3**).
- b) Install one nut (**pos 5**) on each stud (**pos 4**).
- c) Install one insulated fishplate (**pos 1**) taking care that the ribs are toward the rail web and that the writing TENCONI are positioned on the top side.
- d) Install two washerplates (**pos 3**) on that fishplate and insert the studs with the nuts using a light hammer.
- e) Install the second insulated fishplate (**pos 1**) as in c).
- f) Install the two washerplates (**pos 3**) and the nuts (**pos 5**).

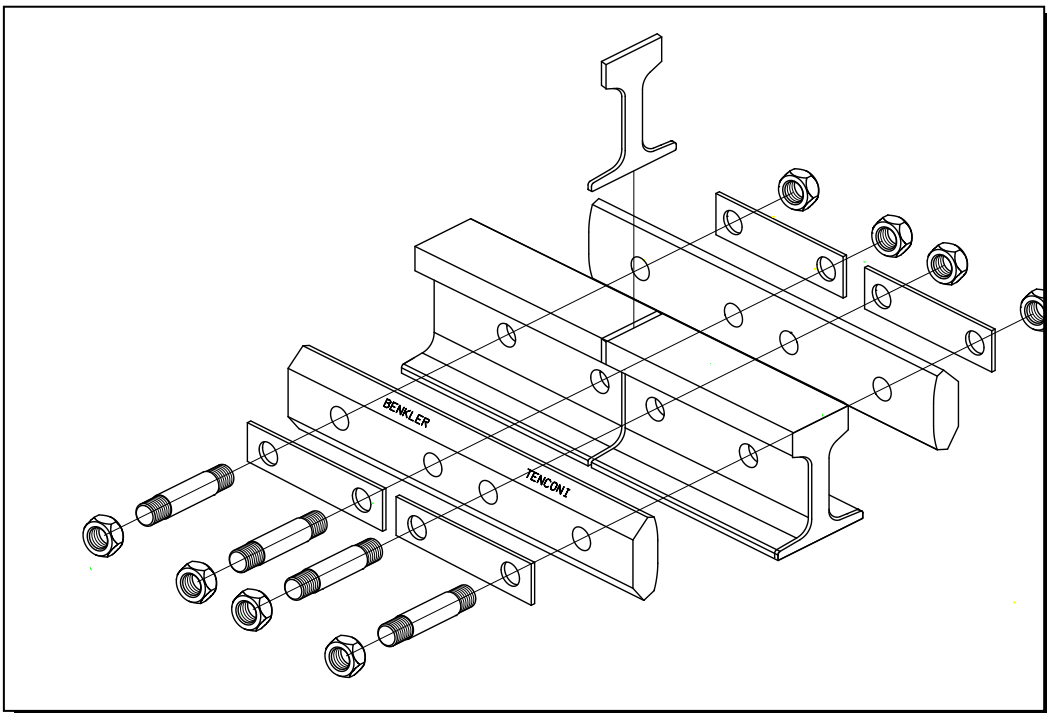

4 JOINT LOCKING

- a) Tighten all the nuts slightly.
- b) Tighten the nuts completely with a torque spanner in the sequence **2, 3, 1** and **4**.
- c) The torque of **760Nm** shall be applied.
- d) Remove the excess plastic of the End Post from the running surface using a chisel or file.

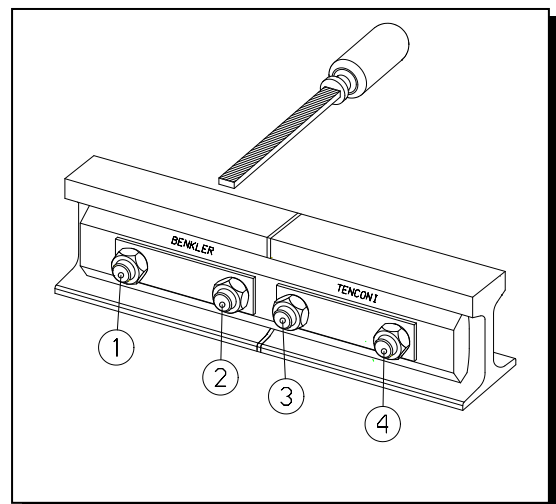

5 RETIGHTENING OF THE NUTS

- a) One month after installation the nuts must be retightened using the above indicated torque value.

Maintenance Instructions

The Tenconi Insulated Joints need to be regularly maintained and cleaned. In particular iron dust traces and other scraps left by trains on the rails can create conductivity between two rail ends, what would disable the operation of the insulated joints.

6 MAINTENANCE

- a) Maintenance is limited to periodical cleaning of the fishplate, particularly around the End Post area in order to avoid electric contacts between the two rails.
- b) Maintenance frequency depends on traffic and local environmental conditions.

7 SPECIAL INSTRUCTION

- a) During periods of cold weather the opening of the gap at the End Post may be observed. This event does not represent a failure of the joint, whose integrity and functionality are still guaranteed.

LOCAL REPRESENTATIVE

MANUFACTURER



AWI MASKIN AB
Hammarvägen 19
SE-23237 Arlöv

www.awi.se

Jan Nilsson

Managing Director

Tel: +46 150-727 17

Fax: +46 150-727 49

Mobil: +46 70-545 25 82

E-mail: jan.nilsson@awim.se

Björn S. Hansen

Orders

Tel: +46 40 43 99 54

Fax: +46 40 41 65 75

Mob: +46 707 20 18 31

E-mail: bjorn.s.hansen@awim.se



Tenconi SA
Via della stazione 50
6780 Airolo
Switzerland

Tel: +41 91 873 30 00

Fax: +41 91 873 30 01

E-Mail: tenconi@tenconi.ch

Web: www.tenconi.ch